

# Dolphin

by Dave Brill

for Jamie Kelley, with grateful thanks.

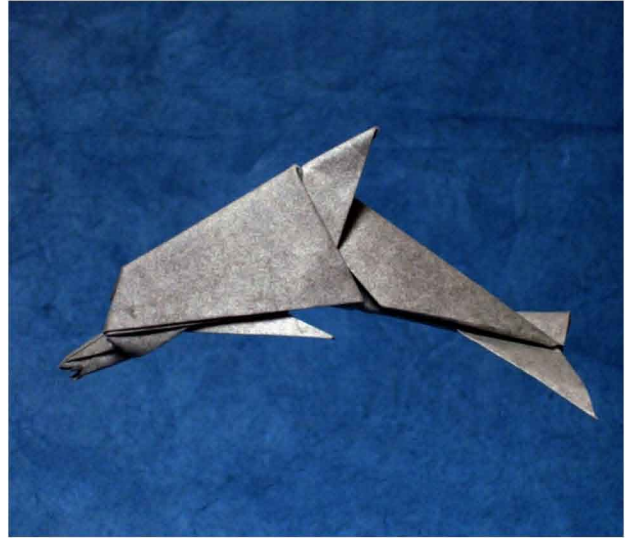

1

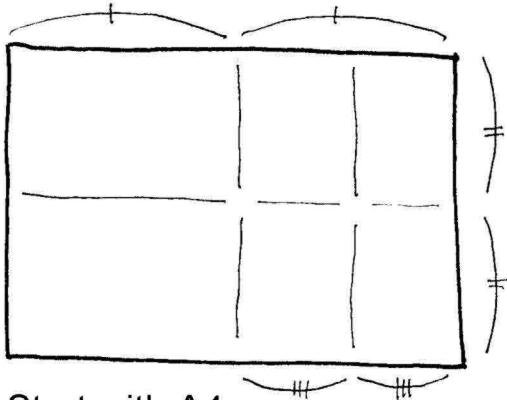

Start with A4  
or larger Silver Rectangle

2

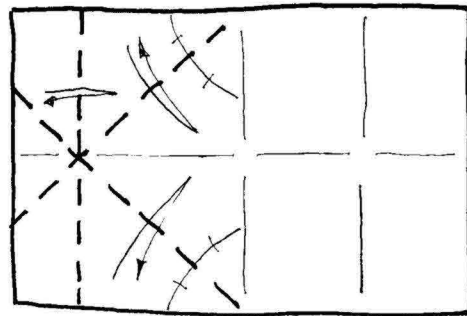

3

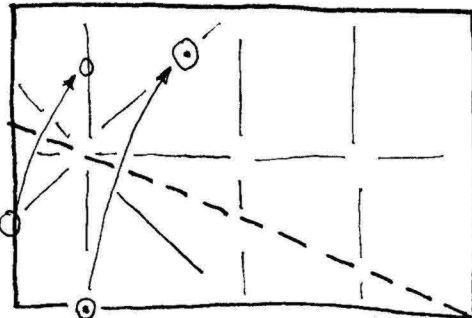

Valley noting the location points

4

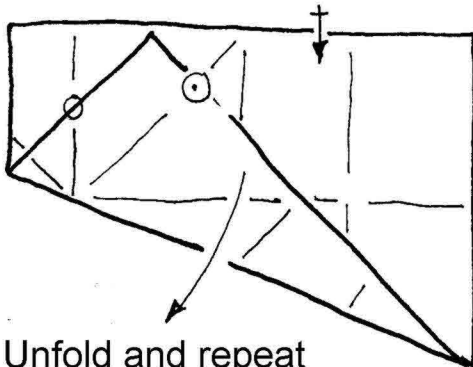

Unfold and repeat  
step 3 with upper half

6

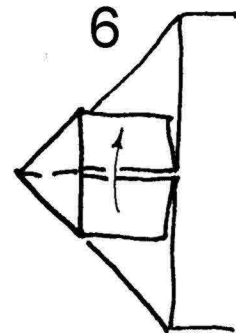

5

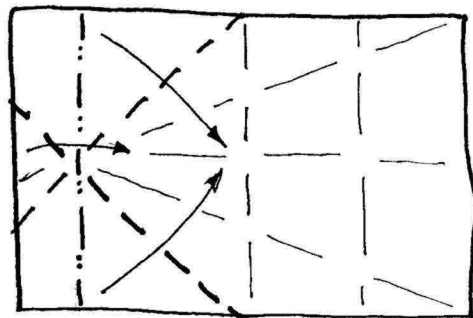

form a "waterbomb" base

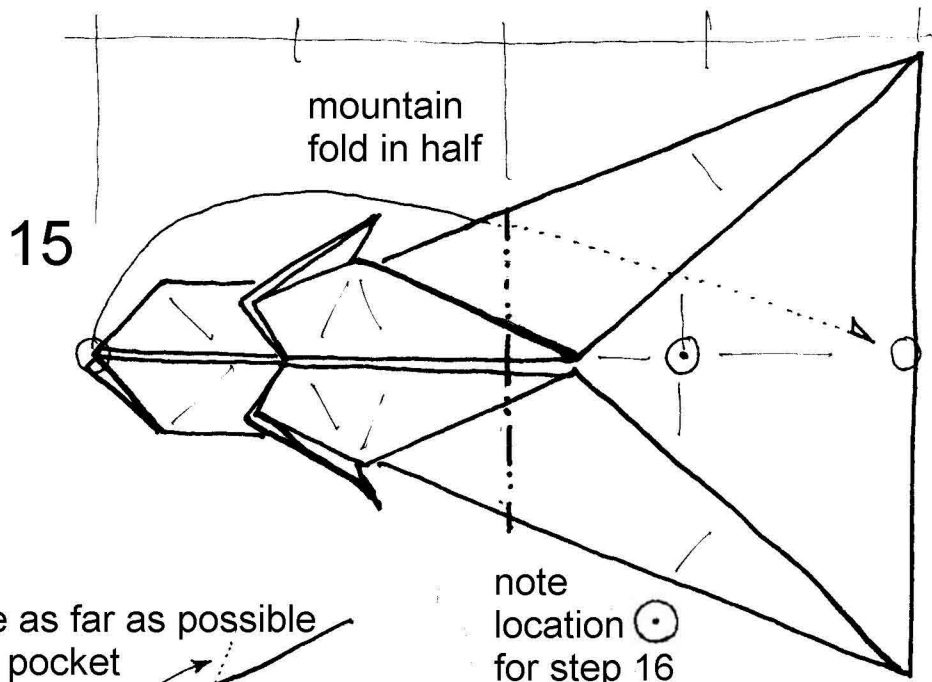

14  
b) reverse as far as possible within the pocket

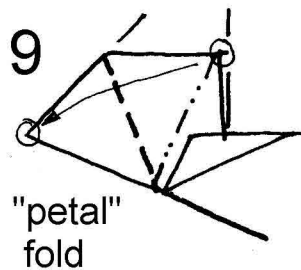
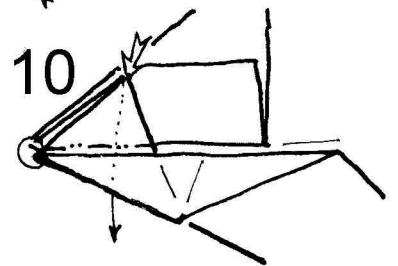
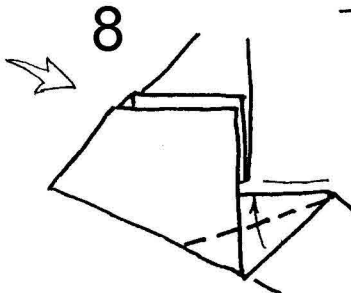
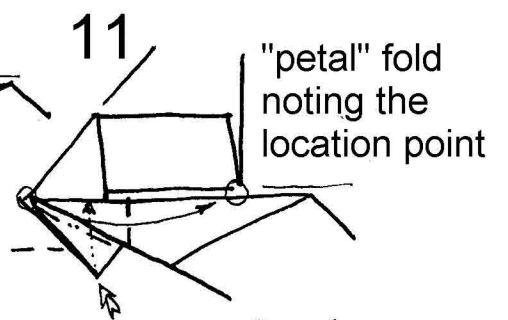
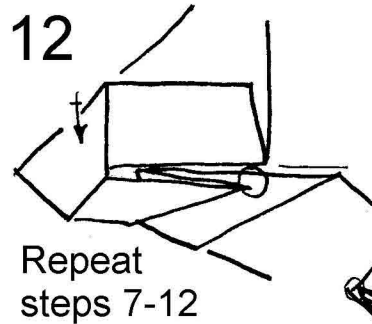
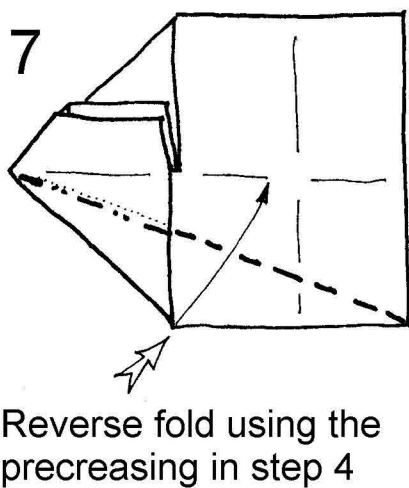
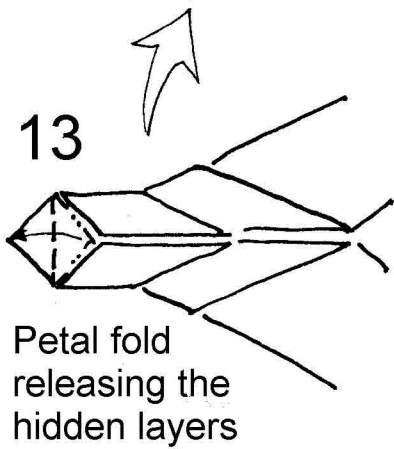
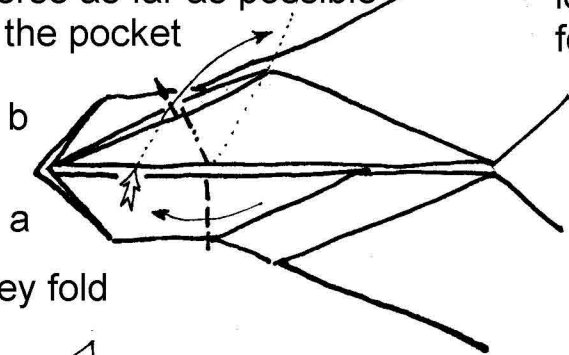

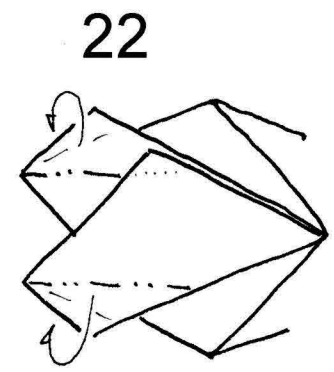
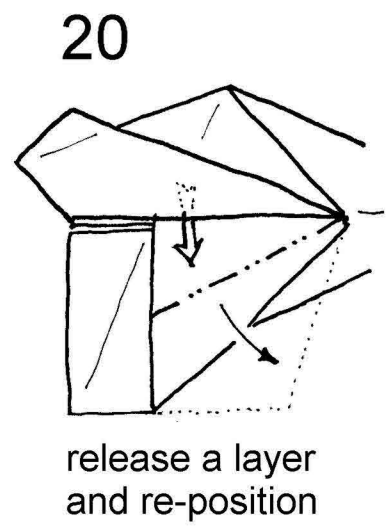
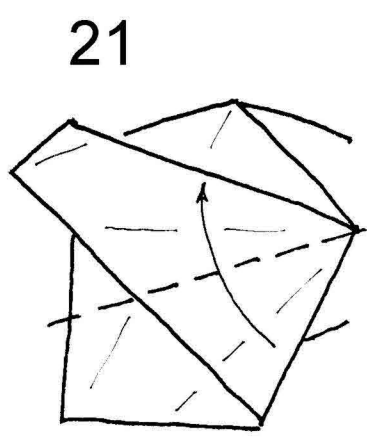
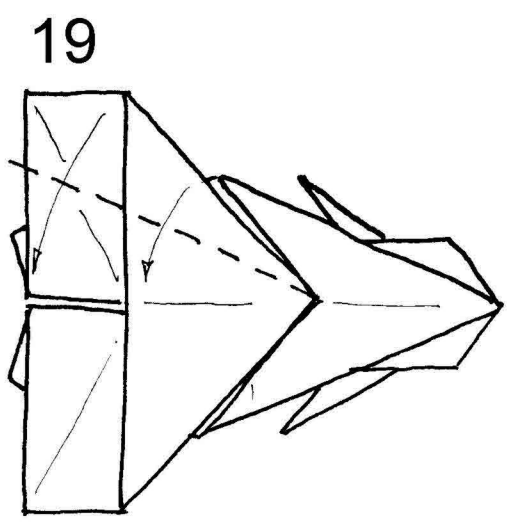
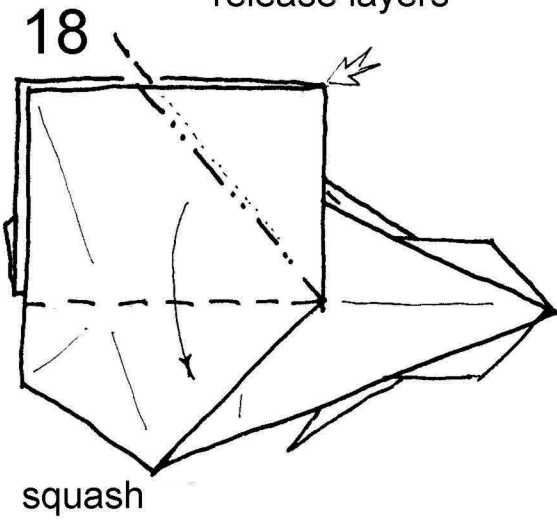
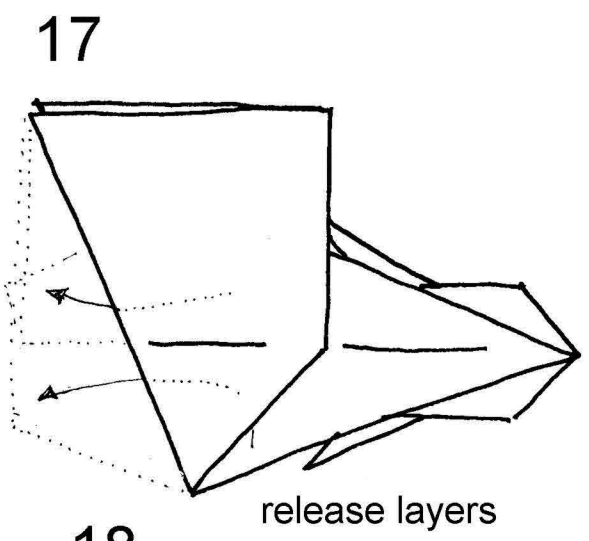
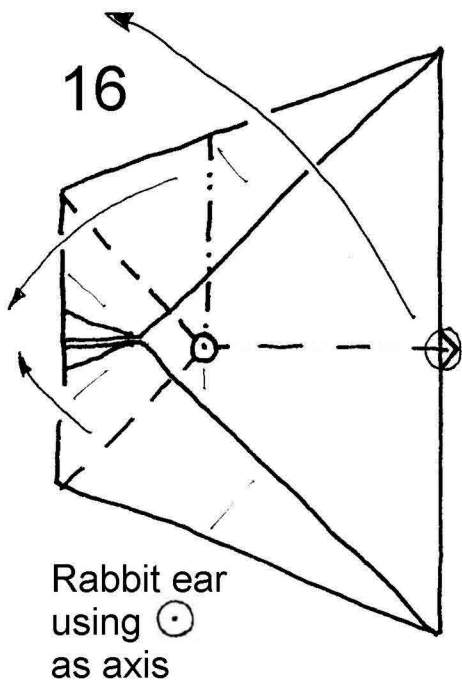

rabbit ear  
the dorsal fin

26

• 2/3 1/3

pleat tail fin  
to match the  
other half

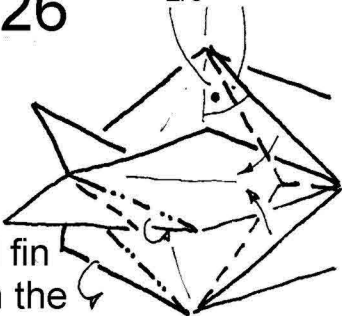

27

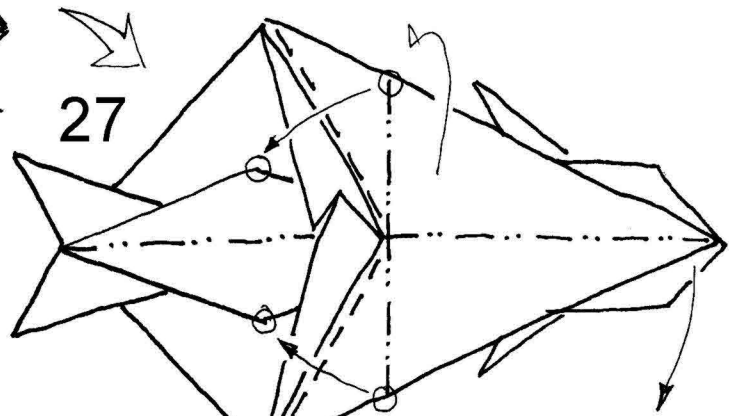

Fold in half and crimp the  
front section.  
Location points almost meet!

25

valley fold  
over and over

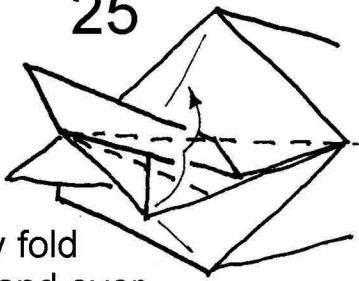

24

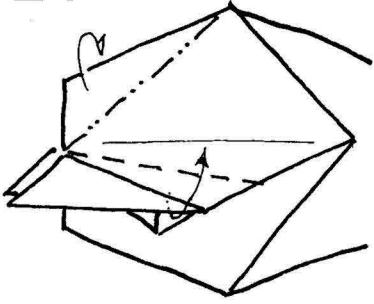

28

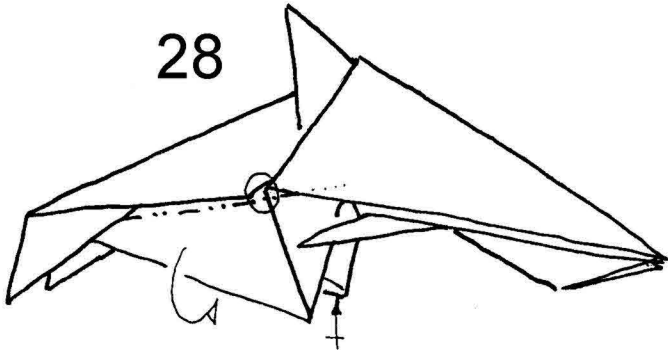

29

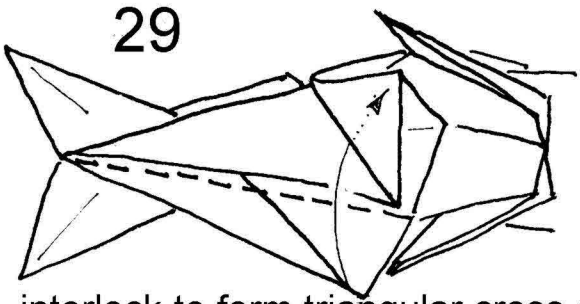

interlock to form triangular cross-section

23

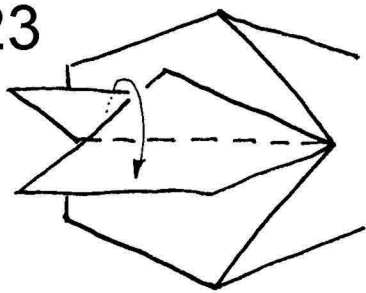

30

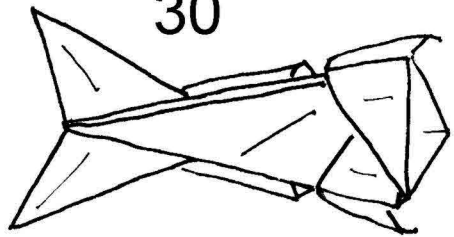

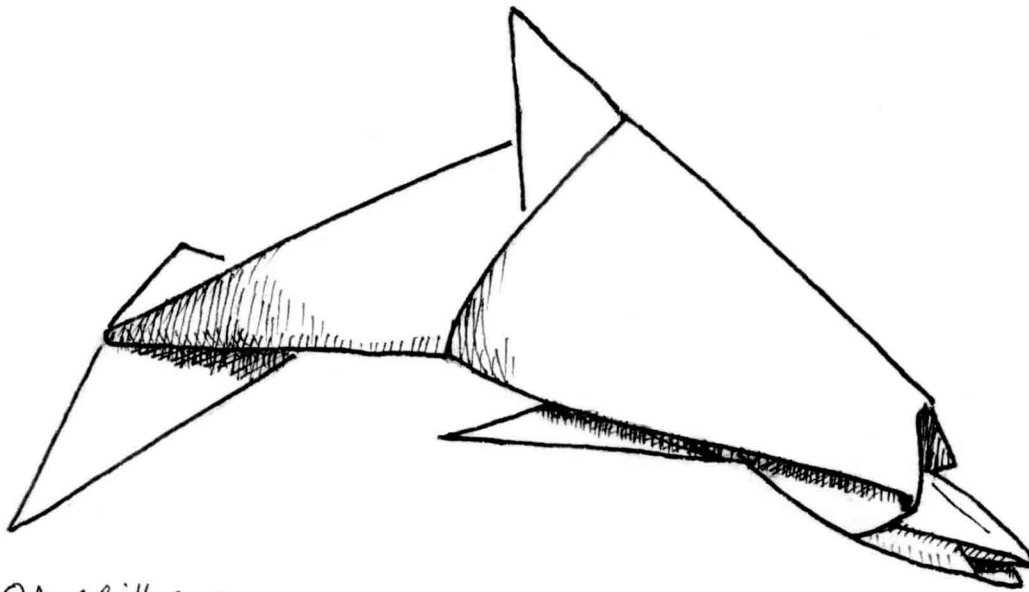

© Anne Brill 2008

