

ORIGAMI SYMBOLS

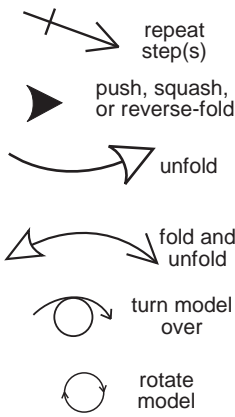

COMMON BASES

"Preliminary" base

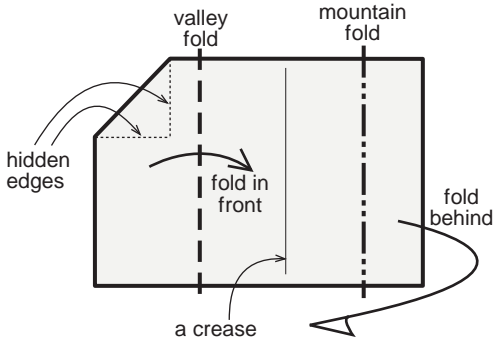
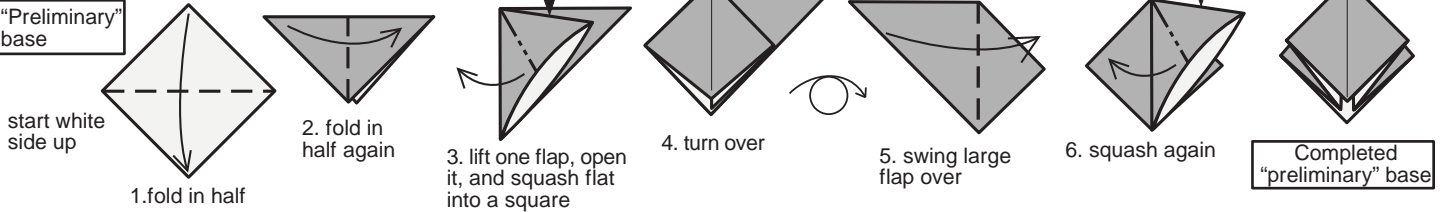

"Waterbomb" base

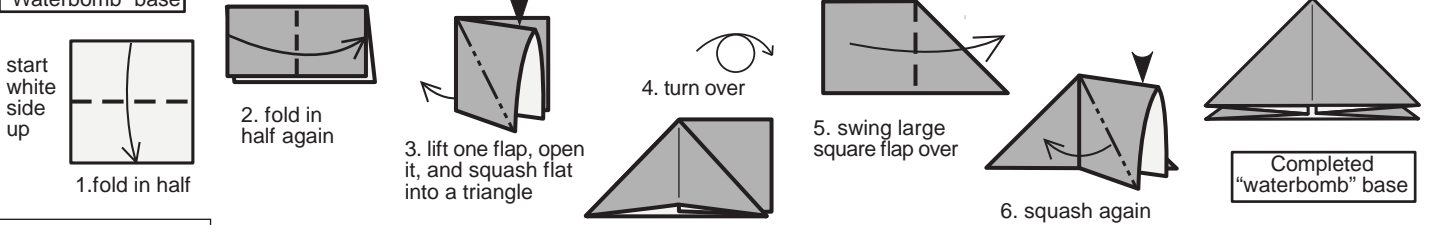

WATERBOMB

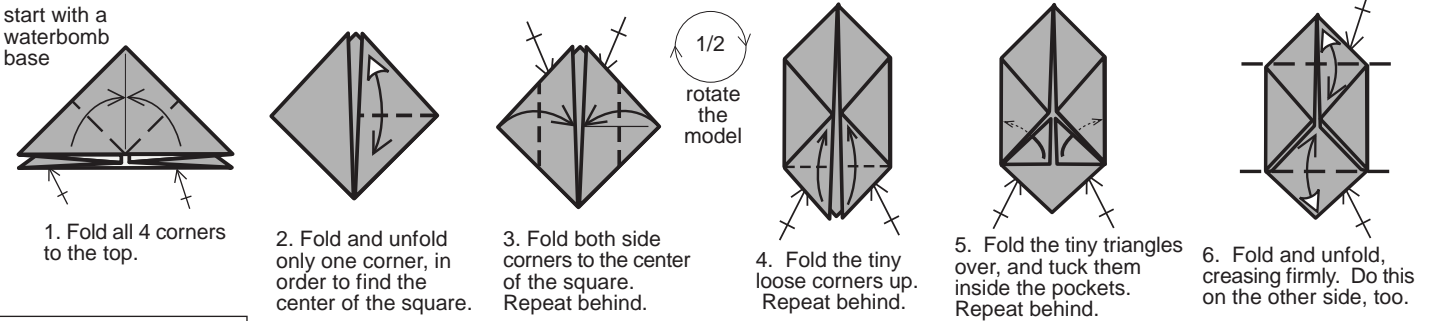

JUMPING FROG

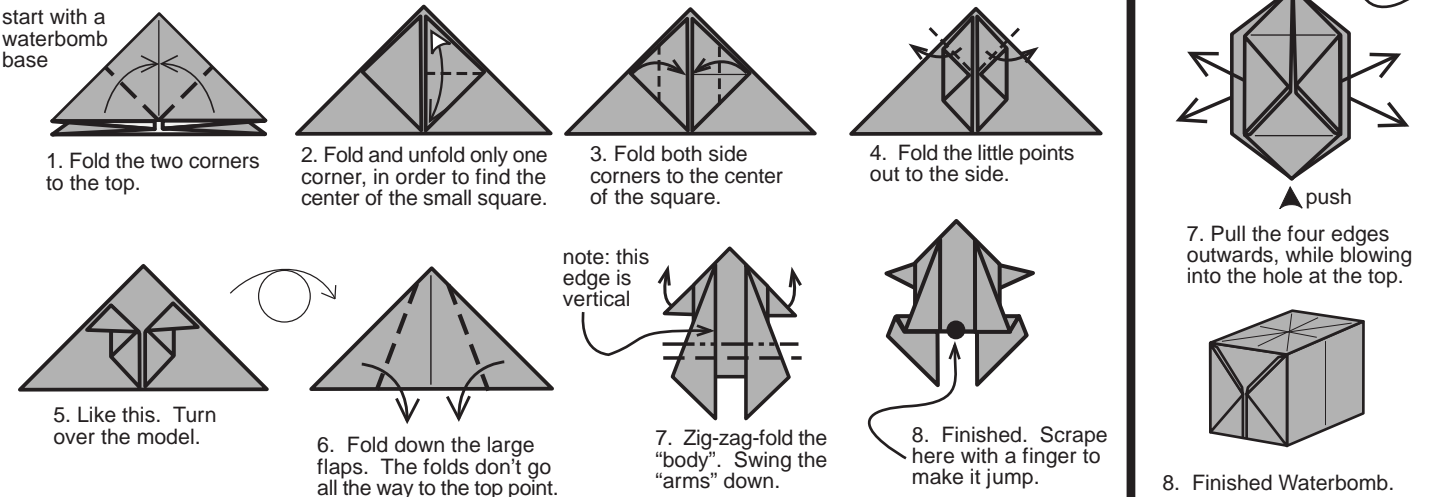

SAMURAI HELMET

start with the white side up

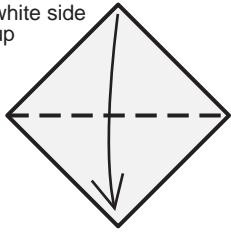

1. Fold in half diagonally.



2. Fold the side corners down to the bottom corner.



3. Fold the loose points up to the top.

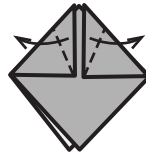

4. Fold the little top points out to the sides.



5. Fold up the upper layer only. Not all the way up!



6. Fold over the thin strip.

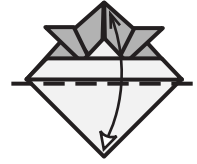

7. Fold the bottom point to the top, and unfold it.

TALKING BIRD

start with the white side up

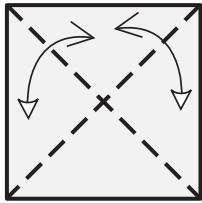

1. Crease along the diagonals.

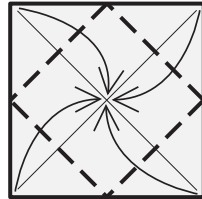

2. Fold all 4 corners to the center (a "blintz" fold).

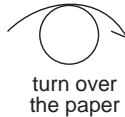

turn over the paper

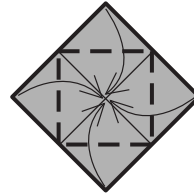

3. Fold the corners to the center again.

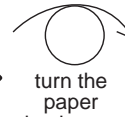

turn the paper back over

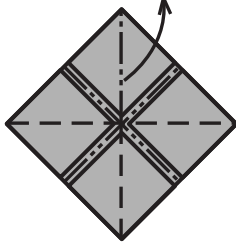

4. Pinch the corners from underneath. On the top corner, let the square pop out.

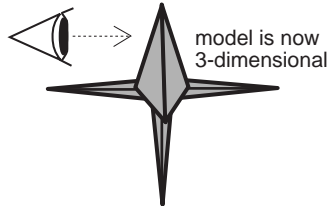

model is now 3-dimensional

5. The next view is from the side.

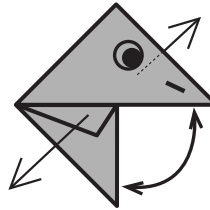

beak opens and closes

6. Draw on the face. Pull the wings outwards to make it talk.

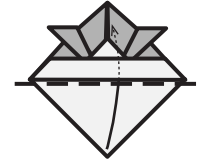

8. Using the same crease, tuck it inside.



9. Spread open the helmet from beneath.



10. Flip the tips of the corners over.

SHIRIKEN

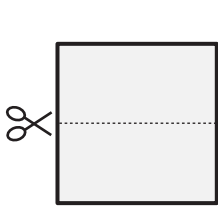

1. Cut or tear a square in half.

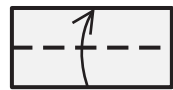

2. Fold each piece in half the long way.



3. Fold the corners at 45°. Be careful: these are mirror images!

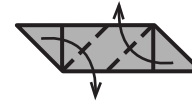

4. More 45° folds.

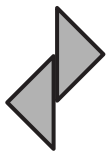

turn over both pieces



5. Like this.

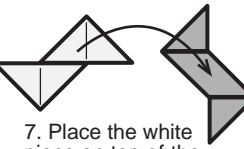
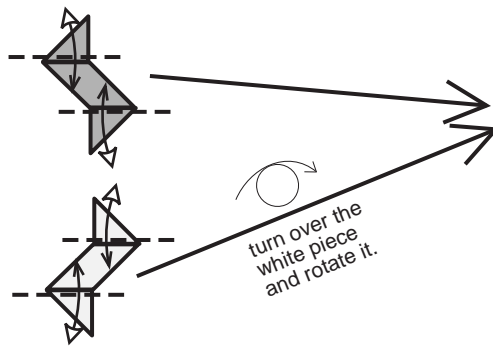

7. Place the white piece on top of the colored piece, forming a cross.

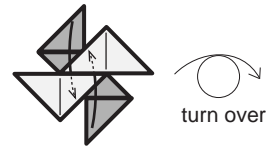

8. Tuck the colored triangles under opposite white edges.

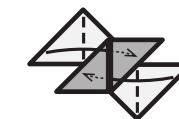

9. Tuck in the white triangles in the same way. This may need a little shifting.

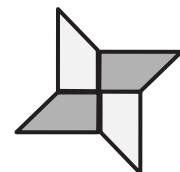

10. Finished Shiriken.



11. Finished Samurai Helmet.