

Fantôme de moine Ghost Monk



- Création # 11 / Date : 03/2003 20 min
 - Niveau / Level : Simple / Simple
 - Dimension (R= 0,46) :
 Un carré de 15 cm donne un modèle de 7 x 4,5 cm.
 A 15 cm square makes a 7 by 4,5 cm model.

Papier / Paper :
 Papier classique / Standard paper
 Papier sandwich / Tissue-foil
 Papier mouillé / Wet folding

Ce modèle est le premier personnage que j'ai créé. Il est né lors de l'élaboration de différentes séquences de plis qui amènent un effet 3D. L'étape 15 en est un exemple.

J'ai développé ce modèle à partir de cette séquence. J'aurais pu l'appeler tout simplement "Moine". Cependant, cette capuche vide me faisait plutôt penser à un fantôme. Le modèle est donc devenu un "Fantôme de moine"!

This model is the first character I created. I was working on various folding sequences to give a 3D effect. Step 15 shows an example of this. I developed this model starting from that sequence. I could have simply named it "Monk". However, the hood rather reminded me of a ghost. Hence the model became a "Ghost monk"!

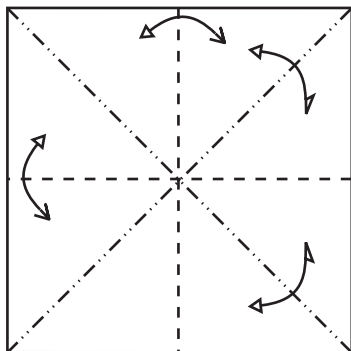
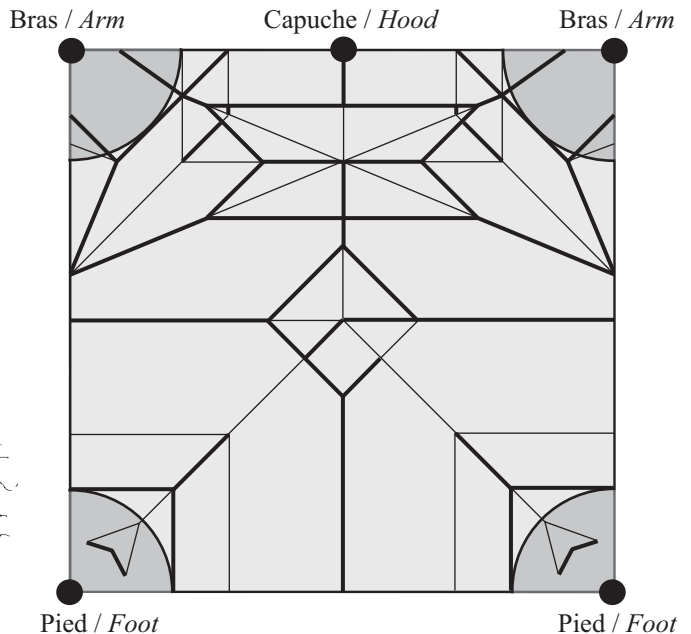
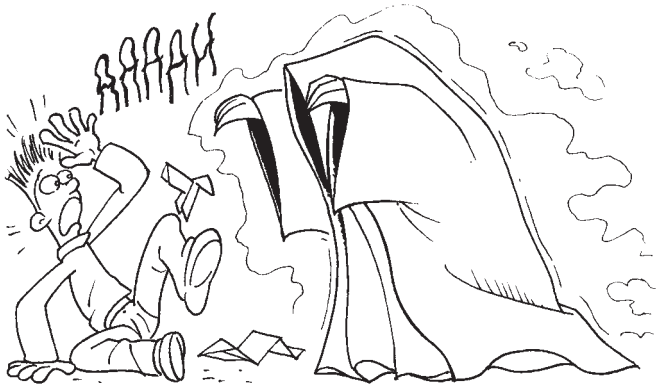

1. Plier et déplier une base préliminaire.
 Fold and unfold a preliminary base.

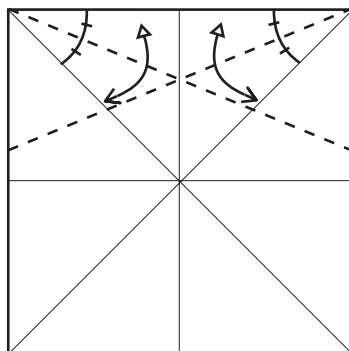

2. Plier les bissectrices et déplier.
 Fold and unfold along angle bisectors.

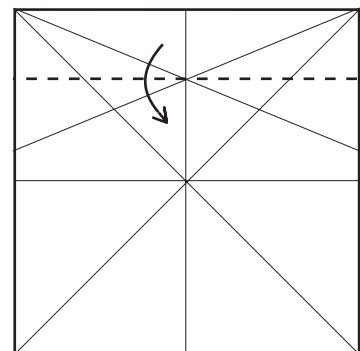

3. Pli vallée.
 Valley-fold.

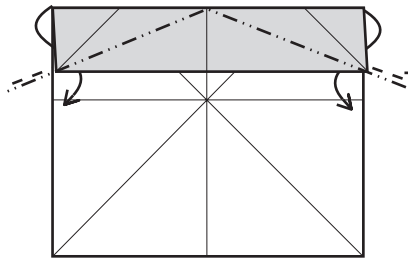

4. Plis inversés intérieurs.
Reverse-fold.

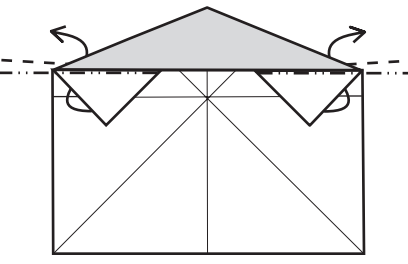

5. Plis inversés intérieurs.
Reverse-fold.

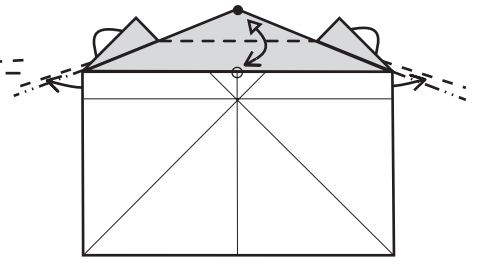

6. Plis inversés intérieurs. Puis plier en deux la pointe et déplier.
Reverse-fold the points at the side. Then fold the top flap in half and unfold.

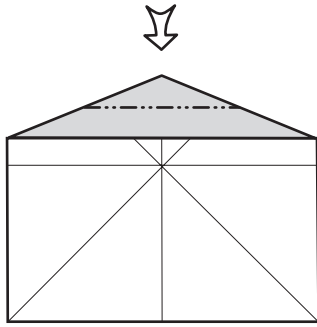

7. Open sink sur le volet.
Open-sink.

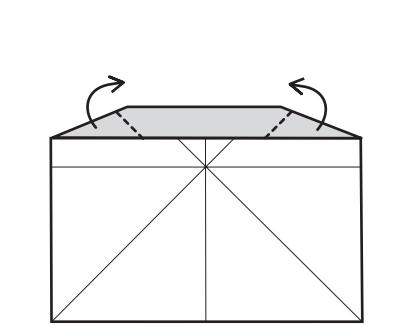

8. Ouvrir les deux volets.
Open the flaps.

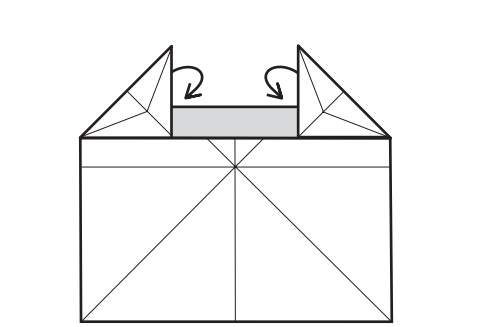

9. Amener les volets cachés vers l'avant.
Bring the hidden flaps to the front.

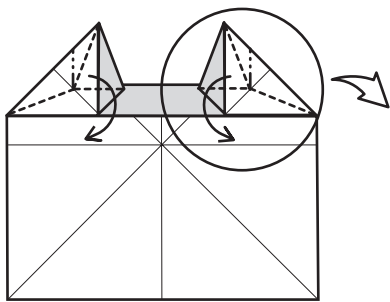

10. Pli oreille de lapin.
Zoom sur un volet.
Rabbit-ear fold. Focus on the right flap.

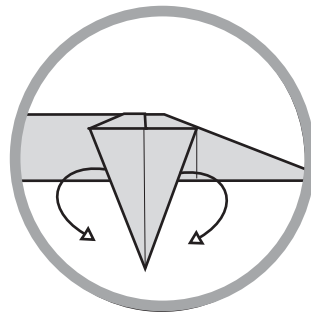

11. Faire glisser vers l'avant les volets cachés.
Slide some paper out to the front.

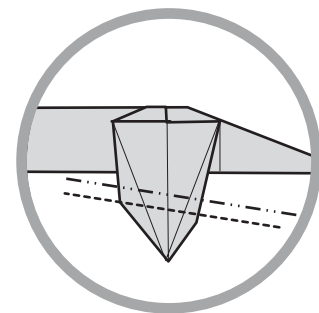

12. Faire un repli pour former la main.
Pleat-fold to create the hand.

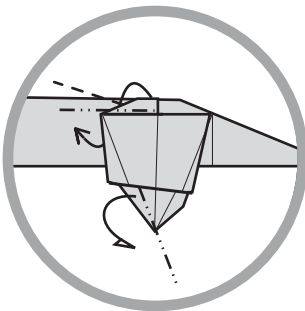

13. Pli inversé intérieur sur le volet du haut. Affiner la main par un pli montagne.
Reverse-fold the top flap. Narrow the hand with a mountain-fold.

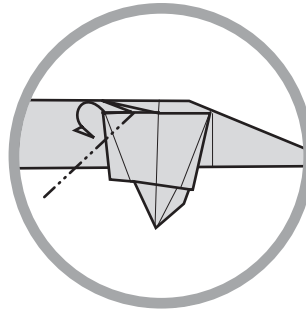

14. Pli montagne sur le coin.
Mountain-fold the corner.

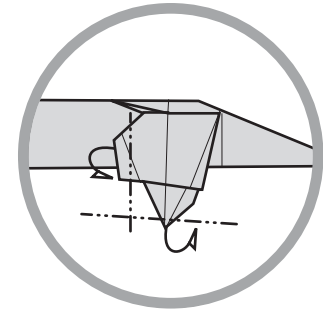

15. Pli montagne pour modeler le bras et la main.
Mountain-fold to shape the arm and the hand.

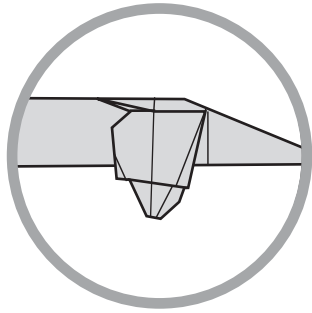

16. Répéter les étapes 11 à 15 sur l'autre bras.
Repeat steps 11 to 15 on the other arm.

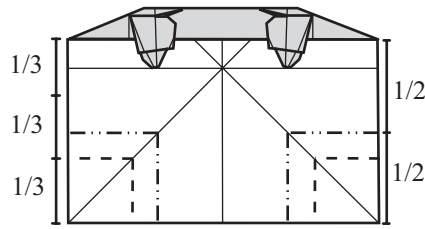

17. Plier à la moitié et au tiers.
Fold and unfold at the half and one third points of the side.

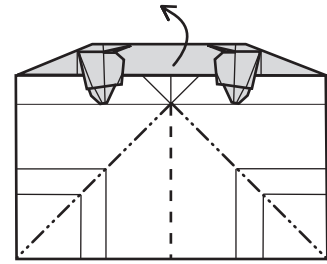

18. Ouvrir le modèle ce qui crée l'effet 3D. En même temps, réaliser deux plis inversés intérieurs.
Open the flap. The model will not lie flat. Make 2 reverse folds at the bottom of the paper at the same time.

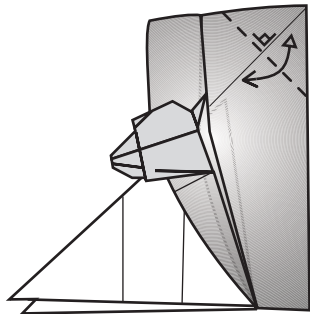

19. Plier et déplier. Puis déplier jusqu'à l'étape 17. Retourner le modèle.
Fold and unfold. Then unfold the model back to step 17 and turn the paper over.

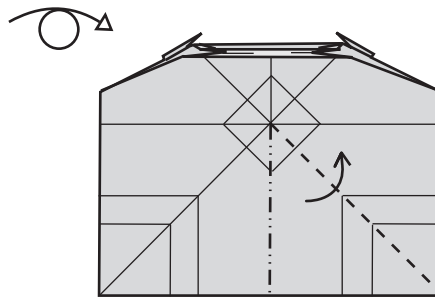

20. Effectuer un repli sur le coin de droite. Le modèle forme une pyramide.
Pleat-fold a corner. The model doesn't stay flat and forms a pyramid.

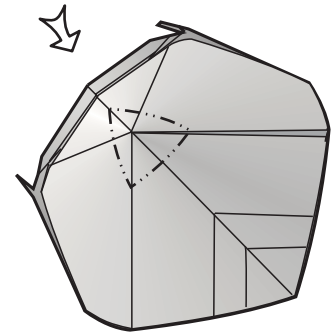

21. Enfoncer la pointe de la pyramide suivant les plis formés à l'étape 18.
Sink the top of the pyramid using the fold made in step 18.

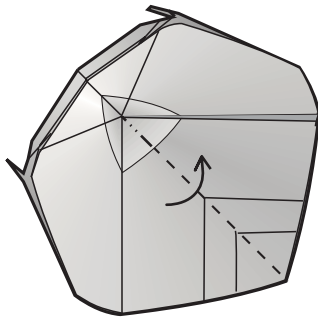

22. Fermer le modèle.
Close the model.

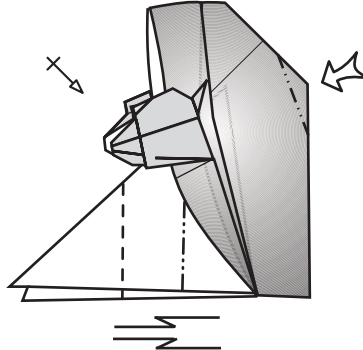

23. Repli double sur chaque volet. Puis réaliser un enfoncement fermé sur le premier volet du dos.
Crimp-folds each leg flap using the creases made in step 17. Closed-sink the top flap at the back.

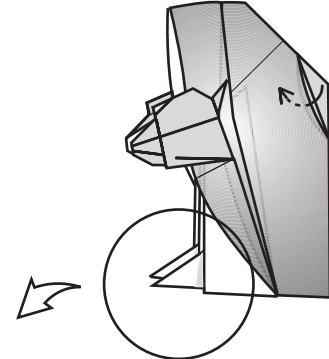

24. Insérer le second volet dans la poche formée à l'étape précédente.
Insert the second flap in the pocket to lock the back of the model. Next, zoom in on the feet.

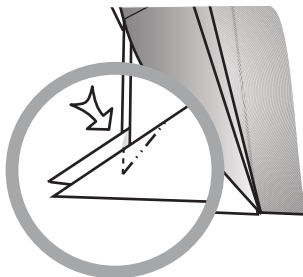

25. Former les pieds avec un effet 3D grâce à un léger enfoncement.
Make a small sink on top of the foot, giving it a 3D appearance.

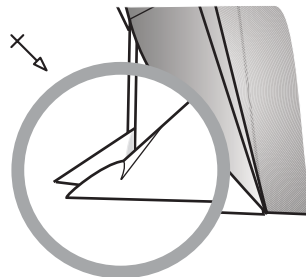

26. Répéter sur l'autre pied.
Repeat on the other foot.

